

CLASS 4 SECTIONS AT ELEVATED TEMPERATURE

Jan Hricák ^a, František Wald ^a, Michal Jandera ^a

^a Czech Technical University in Prague, Faculty of Civil Engineering, Prague, Czech Republic

Abstract

The steel cross-sections behave stable or unstable. The behavior of slender cross sections of steel beams is influenced by local buckling. The buckling can be observed on beam web and/or flange and reduce the load bearing capacity of the beam. Design models adopted for daily design procedures are based on the so-called effective width approach. The design at fire situation is simplified which means that the same effective cross section as for cold design is used neglecting the changes of stiffness of steel. The research is focused on getting the knowledge of behaving of steel beams with welded Class 4 cross-sections exposed to high temperatures. This article describes the progress of the experiments.

Keywords: compressive resistance, temperature, slender cross-sections, class 4 cross-sections

INTRODUCTION

A common practice in recent years, thanks to the introduction of European design standards for building construction has become not only an assessment of the structure at normal design situation, but also in the fire. The area of research slender cross-sections is very important, because the assessment and design principles of Class 4 sections are very specific and usually more difficult than for normal sections. Along with any global problems their behavior includes also local buckling of the compressed part of the cross-section.

The research thesis itself is focused on getting the knowledge of behaving of steel beams from the welded cross sections of class 4 (I and H shape) exposed to high temperatures.

1 THE DESIGN AND PREPARATION OF THE EXPERIMENTS

The focus of the project is to carry out experiments with I - beams with slender cross-sections, which belong to the class 4. The load capacity of these sections is not directly affected by the yield strength of the steel, but by deformations of the compressed areas of the cross-section, i.e. upper wall and the upper flange. To reach this way of deformation of the samples during the planned experiments, it was necessary to choose the appropriate cross-sectional shape, beam load form and force. Four tests with two types of cross-section loaded by four-point bending were carried out. (see Fig. 1).

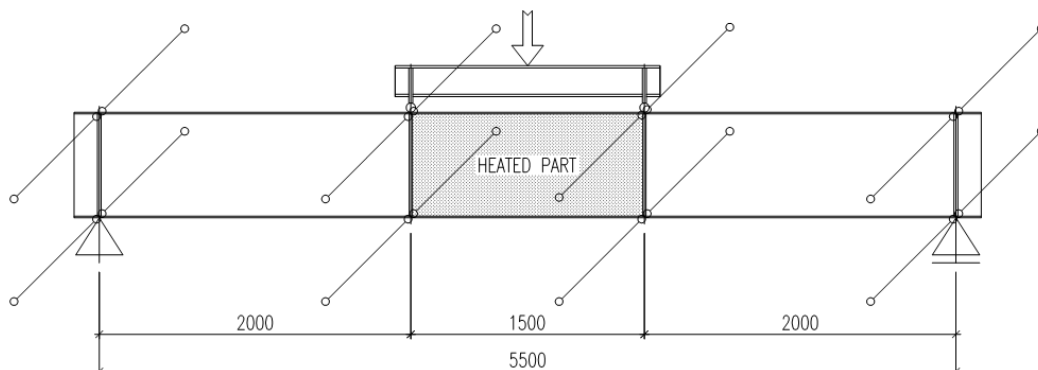

Fig. 1 Static scheme of the experiment

Beams were incur a variable load and they were heated with a constant temperature by an electric heating pads until exhaustion of the load capacity. Each section were heated to a temperature of 450 °C and 650 °C. These experiments were complemented by a number of material tests at high temperatures.

For these experiments, there were two types of welded cross-sections chosen. They represent cross-sections of the 4th class and they are sufficiently burdened by the problematic of local stability of the walls.

- The cross-section A (IW 680/250/12/4) has a vertical strut in the class 4 ($\bar{\lambda}_P = 1,439$) and the flanges are in class 3 ($\bar{\lambda}_P = 0,661$), see Fig. 2a.
- The cross-section B (IW 846/300/8/5) has a vertical strut in the class 4 ($\bar{\lambda}_P = 1,454$) and the flanges are in class 4 ($\bar{\lambda}_P = 1,182$), see Fig. 2b.

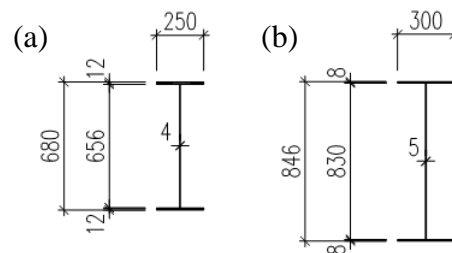

Fig. 2 Cross-sections designed for the experiment: a) Cross-section A, b) Cross-section B

1.1 Production of test samples

There were four beams produced for the experiments, with different length of the heated middle part. Due to thermal expansion and to maintain the static scheme (see Fig. 1), the middle heated part was shortened depending on the operating temperature. When heated to a prescribed temperature the middle part of the beam will have a length of approximately 1500 mm.

The A1 beam (cross-section 680/250/12/4 IS) and B1 beam (cross-section 846/300/8/5 IS) for a temperature of 450 °C were made with the middle part length of 1492 mm. The beams A2 (cross-section 680/250/12/4 IS) and B2 (cross-section 846/300/8/5 IS) designated for a temperature of 650 °C were made with the middle part length of 1488 mm.

1.2 Tools for the experiment

For the smooth running of the experiment and for taking into account all the boundary conditions according to the static scheme (see Fig. 1), steel tools were designed and manufactured. The scheme of the tools layout, including the location of the test beam is shown in the following figure (see Fig. 3).

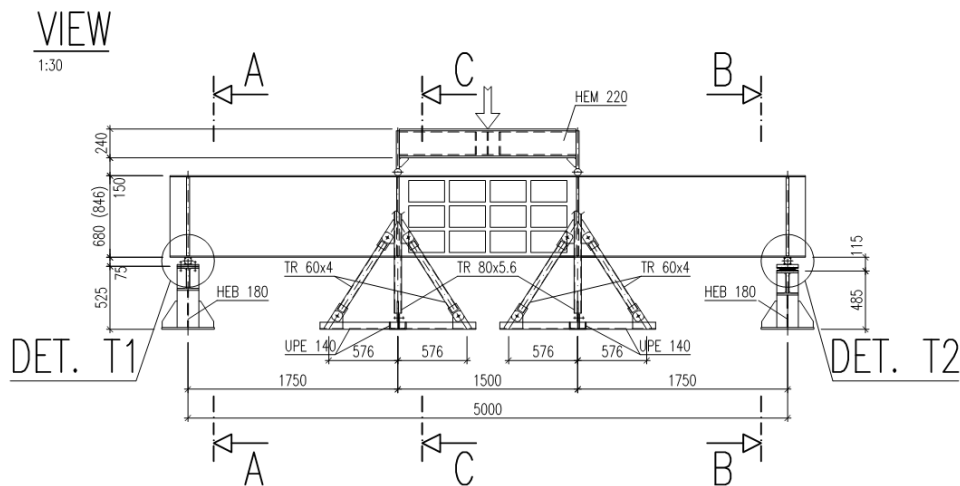

Fig. 3 The scheme of the tools layout

1.2.1 The tools for ensuring the torsional stability

The principle of the tools for ensuring the torsional stability at the support points and at the point of the load input is shown in cross sectional views A-A, B-B and C-C (see Fig. 4).

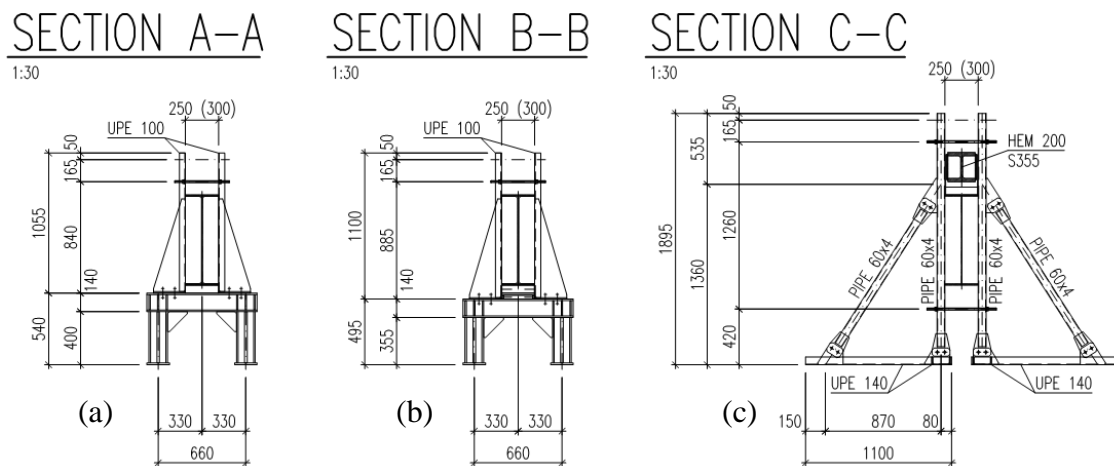

Fig. 4 Views: a) at v the point of the firm joint support, b) at v the point of the sliding joint support, c) at v the point of the load input

The construction of the tools at the support (see Fig. 4a, b) is formed by two vertical guide profiles UPE 100. The horizontal rectification of 240 mm to 310 mm is made possible by a bolt connection with slotted holes in the lower part and the threaded rod at the top part of the tool. The tools for ensuring the torsion stability at v the point of the load input (see Fig. 4c) are formed by the struts, which hold a vertical pair of guide profiles TR 80x5,6. Both the guide profiles are interconnected by a threaded rod at two points.

After placing the test beam to the support, the individual tools will clamp the cross-section of the beam with a small allowance, so a free movement in the vertical and longitudinal directions is not obstructed, but the piece is only prevented from tilting.

1.2.2 The design of the supports

The test beam is, according to the scheme (see Fig. 3), placed on the fixed articulated support from the left side (T1 detail - see Fig. 4) and on the sliding joint support (T2 detail - see Fig. 5) from the right side. The sliding articulated support is designed as a rolling bearing.

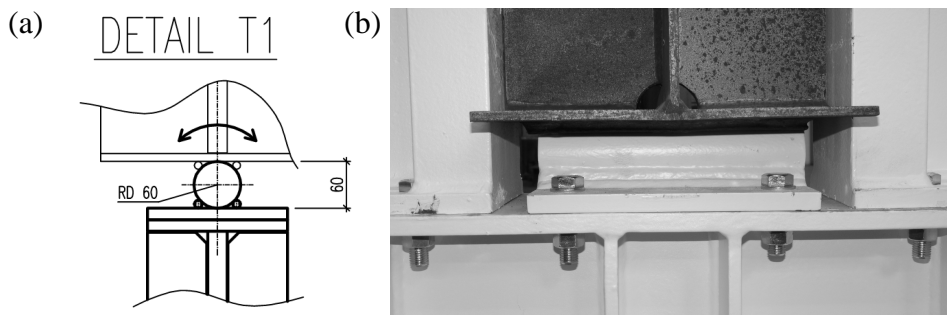

Fig. 5 Fixed articulated support: a) construction detail, b) side view of the finished support

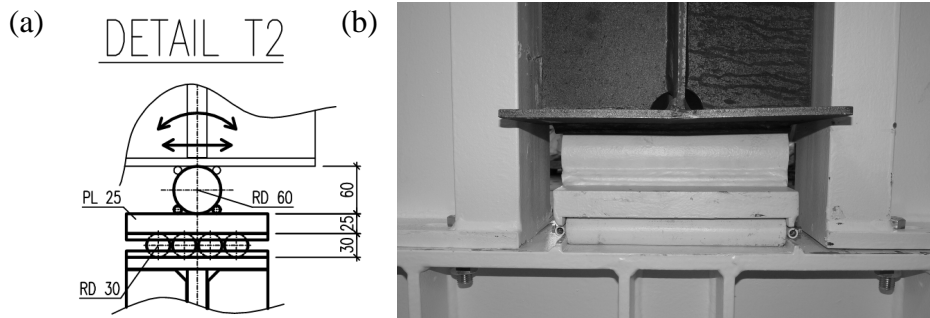

Fig. 6 Sliding articulated support: a) construction detail, b) side view of the finished support

1.3 Distribution of heating pads and sensing devices

The distribution of ceramic heating pads, thermocouples and potentiometers was carried out according to the scheme (see Fig. 7).

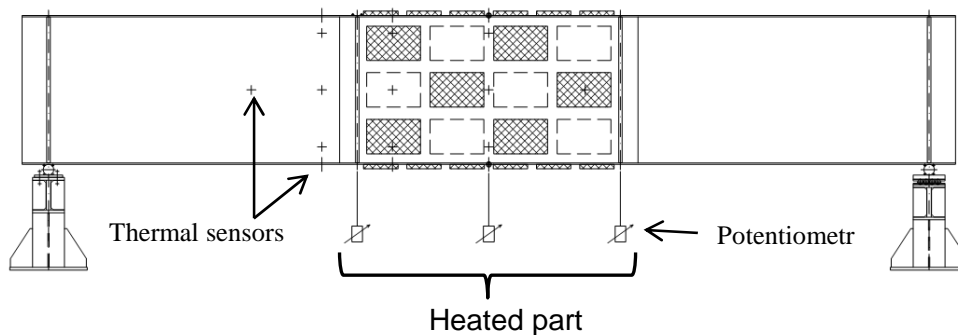

Fig. 7 Scheme of heating pads and sensing devices distribution

1.3.1 Ceramic heating pads

Heating pads 195 x 305 mm were placed on the strut and the flange of the test beam according to the scheme (see Fig. 7). Alternately distributed pads were fastened to the strut using a steel wire grate, which was then fastened by a paper tape. The pads were placed on the flanges only from the outside. The mats on the top flange were loosely laid, and the mats on the bottom flange were fastened by bent wires. The distributed heating pads are seen on these photographs (see Fig. 8). The heating pads are able to reach a maximum temperature of 1200 °C at a heating rate 10 °C/min.

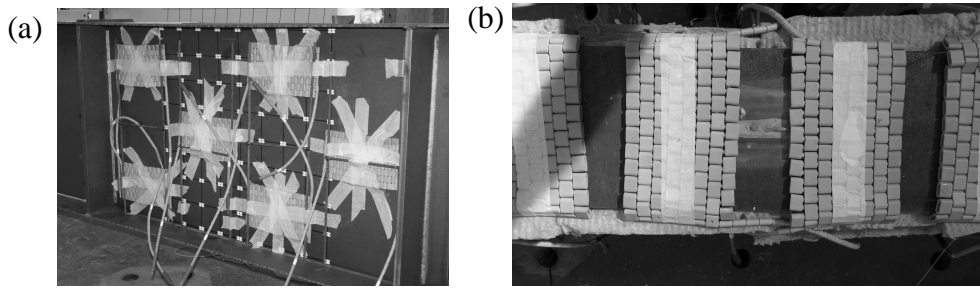

Fig. 8 Photo of the distributed heating mats: a) on the web, b) on the flange

1.3.2 Insulation of the heated central part of the beam

The entire heated middle part of the test beam was wrapped by ROCKWOOL Airrock HD thermal insulation boards. The space between the flanges was filled by the Insulation boards and strips of thermal insulation were then placed on both flanges. Thus insulated beam was then tied by a wire. The insulation procedure of the test beam is shown in Fig. 9. Finally, the whole middle part was wrapped by SIBRAL insulating strip.

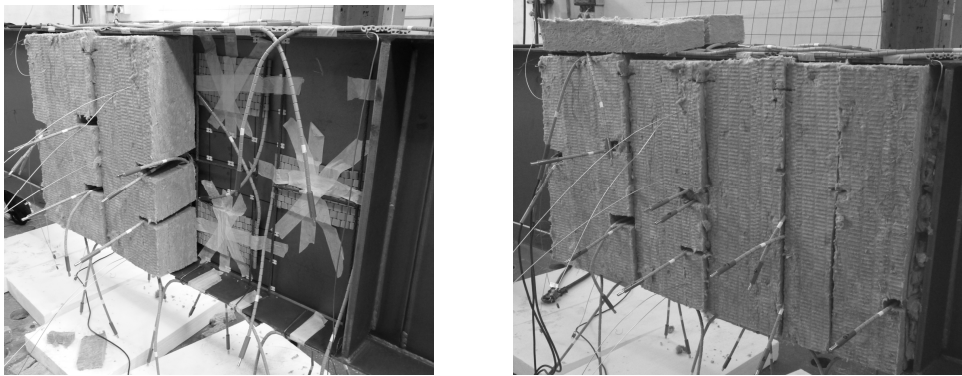

Fig. 9 Insulation procedure of the test beam

2 PROGRESS OF THE EXPERIMENT

After connecting all sensing devices (thermocouples, potentiometers, dynamometr in a hydraulic press) to the central measuring equipment and after connection the heating mats to the transformer, the beam was ready for the experiment (see Fig. 10).

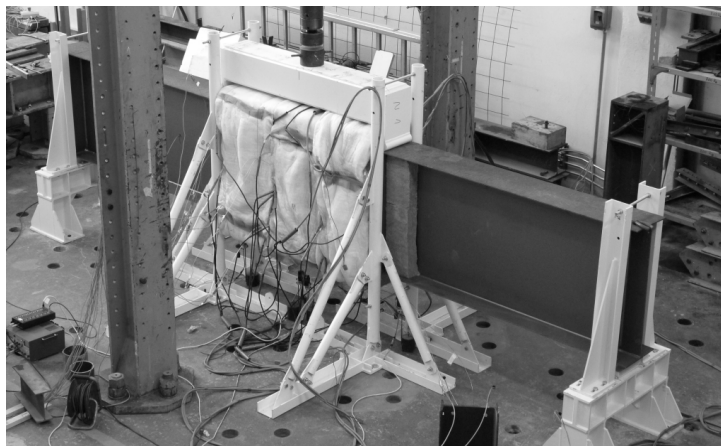

Fig. 10 The prepared test beam prior the experiment

A manual mode was chosen for heating, which allowed controlling of the performance of the heating mats on the basis of information from the thermocouple, displayed on the measuring device. Warm-up time for the temperature $T \approx 450 \text{ }^\circ\text{C}$ was ~ 45 minutes and ~ 65 minutes for

the temperature $T \approx 650 \text{ }^\circ\text{C}$. After reaching the desired temperature in the heated part of the beam, a mechanical loading was started. The hydraulic press, which was controlled by a constant proportion of the deflection path in the middle part of the heated beam, was affecting the test beam through the load beam. The test beam was thus strained by four-point bending. The following load-deflection diagrams for Test 1-4 (see Fig. 11) express the dependence of the applied load of the press and the deflection in the middle of the heated part of the of the test beam. Summary of the results is shown in Tab. 1.

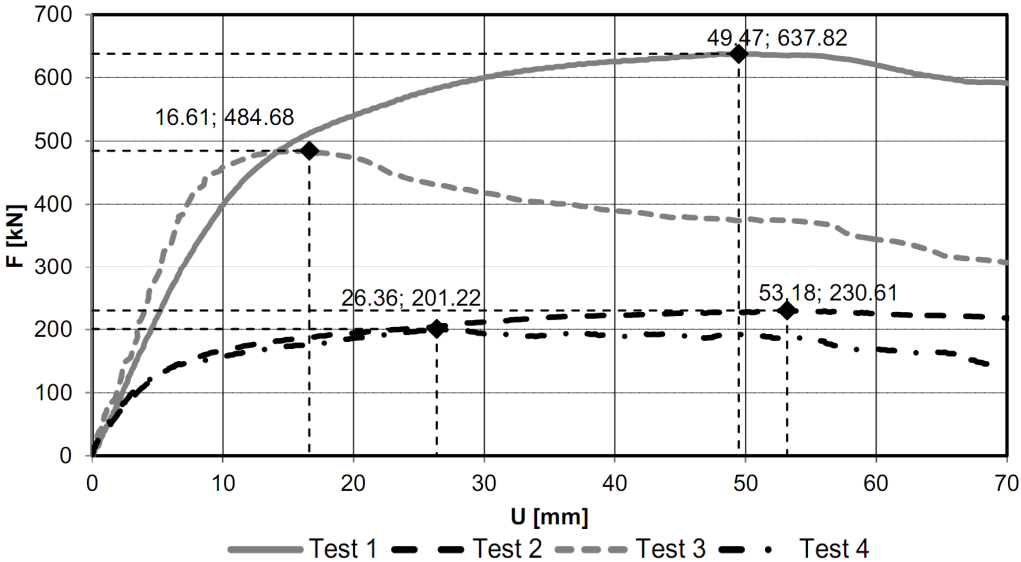

Fig. 11 Load-deflection diagram

Tab. 1 Load capacity from experiments

Tests	Cross-Section	Load capacity [kN]
1	A (IW 680/250/4/12)	637.82
2	A (IW 680/250/4/12)	230.61
3	B (IW 846/300/5/8)	484.68
4	B (IW 846/300/5/8)	201.22

3 CONCLUSION

The previous numerical model will be modified according to the actual material properties and according to the actual temperature. In this numerical model will be performed a parametric study. These studies will lead to the formation of a more precise design method for a sections class 4 at a high temperature.

REFERENCES

Buchanan A. H., Structural Design for Fire Safety, New Zealand, 2001.
 Trahair, N. S., Bradford, M. A., Nethercot, D. A., The Behaviour and Design of Steel Structures, London, 2001.